



Piezoelectric pressure transducer

FEATURES

- Designed for use in gas turbines
- Temperature range :
-70 °C to 560 °C (-94 °F to 1 050 °F)
- Outstanding thermal behaviour (no pyroelectricity)
- Sensitivity virtually constant over product lifetime
- Very low response threshold
- Internal case insulation



DESCRIPTION

The use of piezoelectric single-crystal in the CP 502 dynamic pressure transducer makes it an extremely stable and reliable device.

The transducer is applicable to either long-term monitoring of pressure pulsation in gas turbines or development testing.

The industrial-grown single-crystal GaPO_4 guarantees excellent signal quality and constant sensitivity.

It is fitted with an integral mineral insulated cable (twin conductors) which is terminated with a LEMO connector.



The information contained in this document may be subject to export control regulations of the European Community, USA or other countries. Each recipient of this document is responsible for ensuring that the transfer or use of any information contained in this document complies with all relevant export control regulations. ECN N/A.

MECHANICAL DRAWING

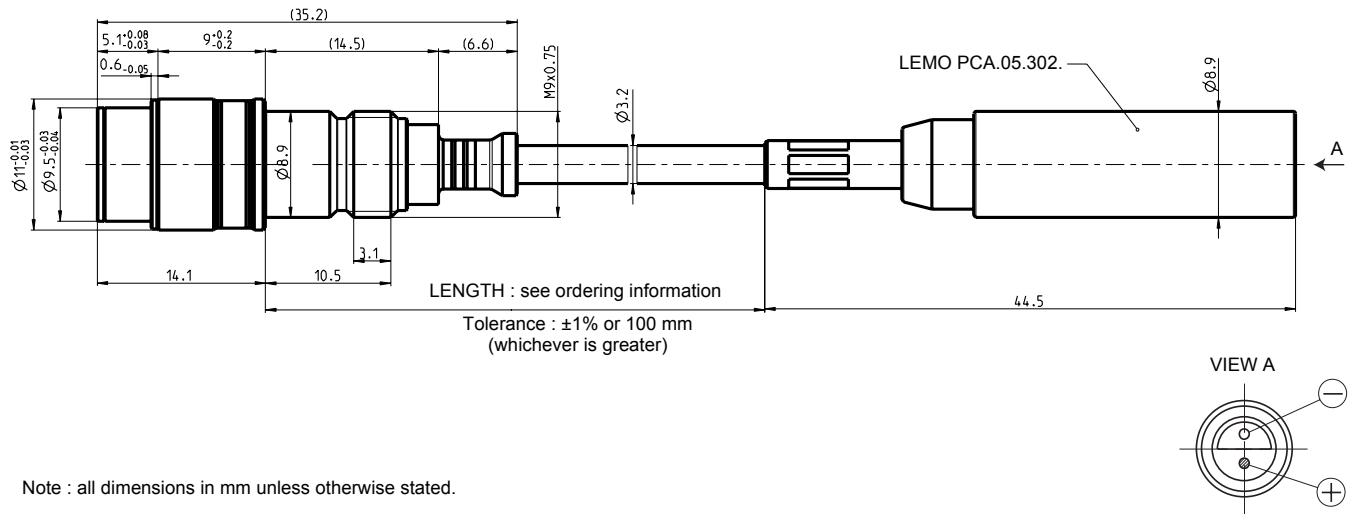

SPECIFICATIONS

GENERAL

Input power requirements	: None
Signal transmission	: 2-pole system insulated from casing, charge output
Signal processing	: Charge converter

OPERATING

Sensitivity (typical)	: 85 pC/bar (5.9 pC/psi)
Dynamic measuring range (random)	: 0 to 50 bar (0 to 725 psi)
Burst pressure	: >100 bar (>1 450 psi)
Linearity	: ≤ 0.5% over dynamic measuring range
Acceleration sensitivity	
• Axial	: ≤ 2 mbar/g (≤ 0.03 psi/g)
• Radial	: ≤ 0.2 mbar/g (≤ 0.003 psi/g)
Frequency response	: 2 to 15 000 Hz ±5% (lower cut-off frequency is determined by the electronics used)
Resonant frequency	: > 50 kHz (along sensitive axis)
Transducer capacitance (including 1 m cable)	: 122 pF nominal pole/pole, 157 pF nominal pole/ground
Internal insulation resistance	: > 10 ¹⁰ Ω at 25 °C (77 °F), > 10 ⁶ Ω at 560 °C (1 050 °F)

ENVIRONMENTAL

Temperature range (continuous operation)	: -70 °C to +560 °C (-94 °F to +1 050 °F)
Housing material	: Nimonic 90, hermetically welded
Mounting torque	: See mechanical drawing
Connection type	: 2-pole hard line cable (ø3.2 mm), insulated from casing, LEMO Connector

CALIBRATION

ISO 9001 certified calibration at +20°C with dead weight tester (3, 6, 8, 10, 12, 30, 50 bar). Sensitivity and linearity are determined according to DIN 16086.

TYPICAL RESPONSE CURVE

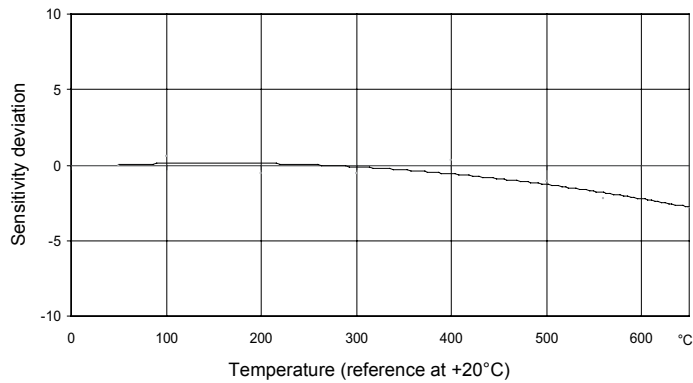

ORDERING INFORMATION

To order please specify :

Type	Designation	Ordering Number	Cable length
CP 502	Piezoelectric pressure transducer	143-502-00-011	2.5 m

ACCESSORIES

MA 104 Mounting Adapter for CP 502 (to be used with VM Lemo Connector)

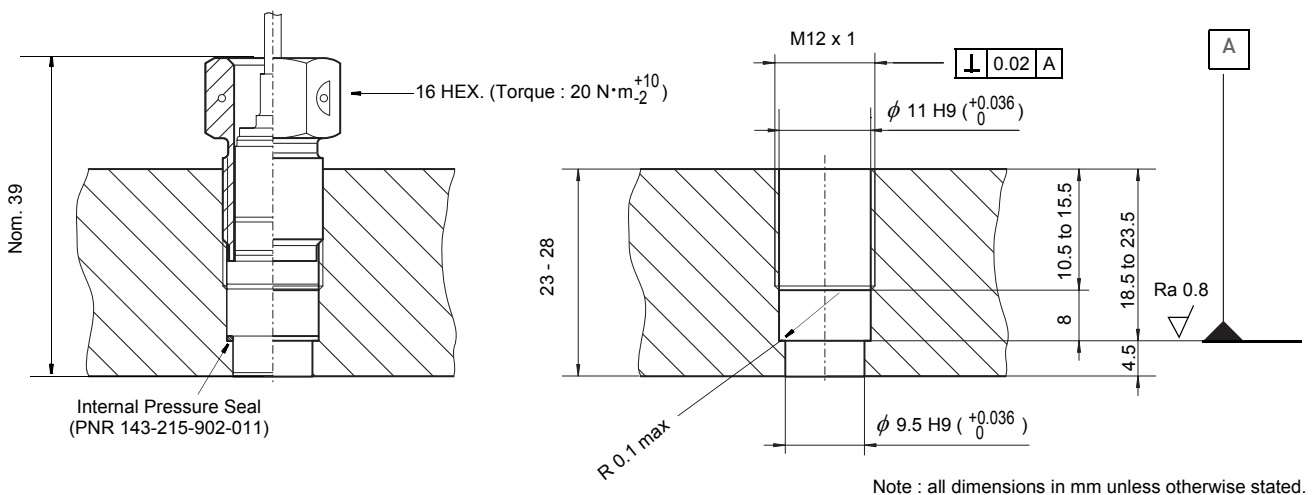

Designation
MA 104 Mounting adapter

Ordering Number
809-104-000-011

ACCESSORIES (Continued)

CP 50X Pressure Seals

Designation	Ordering Number
MA Internal pressure seal	143-215-902-011
MA External pressure seal	143-215-903-011



All statements, technical information, drawings, performance rates and descriptions in this document, whilst stated in good faith, are issued for the sole purpose of giving an approximate indication of the products described in them, and are not binding on Vibro-Meter SA unless expressly agreed in writing. Before acquiring this product, you must evaluate it and determine if it is suitable for your intended application. Unless otherwise expressly agreed in writing with Vibro-Meter, you assume all risks and liability associated with its use. Any recommendations and advice given without charge, whilst given in good faith, are not binding on Vibro-Meter.

Vibro-Meter takes no responsibility for any statements related to the product which are not contained in a current Vibro-Meter publication, nor for any statements contained in extracts, summaries, translations or any other documents not authored by Vibro-Meter. We reserve the right to alter any part of this publication without prior notice.

In this publication, a dot (.) is used as the decimal separator and thousands are separated by spaces. Example : 12 345.678 90.

Sales offices

Vibro-Meter has offices in more than 30 countries. For a complete list, please visit our website.

Your local agent

Head office

Vibro-Meter SA
Rte de Moncor 4
P.O. Box
CH-1701 Fribourg
Switzerland

Tel: +41 26 407 11 11
Fax: +41 26 407 13 01



www.vibro-meter.com

MEGGITT
smart engineering for
extreme environments