

vibro-meter
certified by

CE 254

Piezoelectric Accelerometer Type CE 254

CHARACTERISTICS

- Qualified for flight on Ariane 5 launcher (ESA-CNES-SEP-Arianespace Program)
- Built-in electronics, 5 V output
- Modal analysis accelerometer
- Proven reliability

FEATURES

- 2 wire technique
- Hermetically sealed
- Sensitivity
50 mV/g, 20 mV/g
- Temperature range:
-55°C to +125°C
- Frequency response:
1 Hz to 4500 Hz

WEIGHT: 18 g



DESCRIPTION

The CE 254 is a high-performance, general-purpose accelerometer with a shear mode measuring element.

This design offers a very low frequency phase shift when exposed to different temperatures.

The integral electronics eliminates the need for a charge converter and allows the use of up to several hundred meters of low-cost cable.

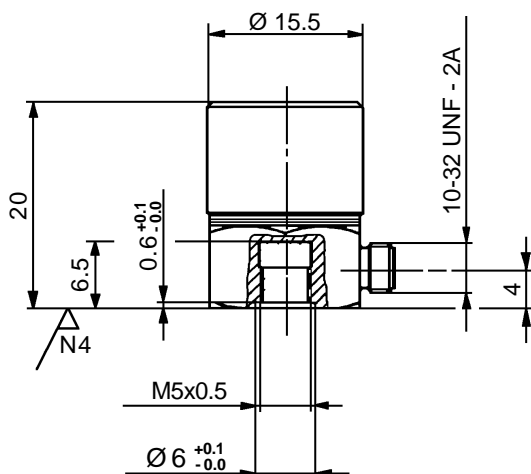
The low 20 μV noise floor gives an extremely high resolution.



DIRECTION OF
ACCELERATION
TO PROVIDE A
POSITIVE SIGNAL

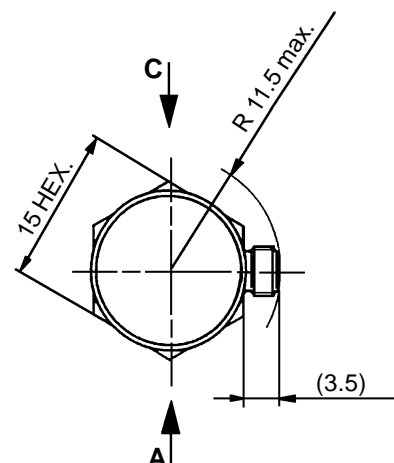
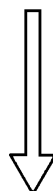

SPECIFICATIONS

CE 254

Input power requirements : Constant current 0.5 to 12 mA min. 22 V
Signal transmission : 2 wire system with modulated voltage output
Signal processing : Power supply (constant current source)

OPERATING (at +23°C ±5°C)
Sensitivity * (at 120 Hz) : 50 mV/g, 20mV/g ±5%
Dynamic measuring range (random) * : 0.001 g to 100/250 g peak
Resonant frequency (mounted) : 24 kHz nominal
Transverse sensitivity : <3 %
Linearity : <1 % over dynamic measuring range
Frequency response : 1 to 2500 Hz ±5 %
Output impedance *
• With 12 mA : 200 Ω
• With 6 mA : 500 Ω
Temperature error : <±2 % over temperature range

Bias voltage * (over temperature range):
• 8 to 14 VDC : 12 mA
• 5 to 10 VDC : 6 mA
Noise floor * : <35 μV typical (12 mA)

ENVIRONMENTAL
Temperature range : -55°C to +125°C
Shock acceleration : <2000 g peak (half sine, 1ms)
Pressure : 35 bar
Base strain sensitivity : <0.001 g/microstrain
Acoustic sensitivity : (under 180 dB SPL) <0.25 g RMS equivalent
Corrosion, humidity : Titanium, hermetically welded
Mounting : On surface roughness max. N6 (Ra ≤ 0.8 μm) stud M5 x 0.5

CALIBRATION
Dynamic calibration at factory at 5 g peak and 120 Hz (+23°C) with 6 mA constant current.
No subsequent calibration necessary.

* A lower constant current reduces the noise floor and the bias voltage, increases the sensitivity and the impedance. A minimum current of 4 mA is necessary to cover the full dynamic range.

Typical Frequency Response

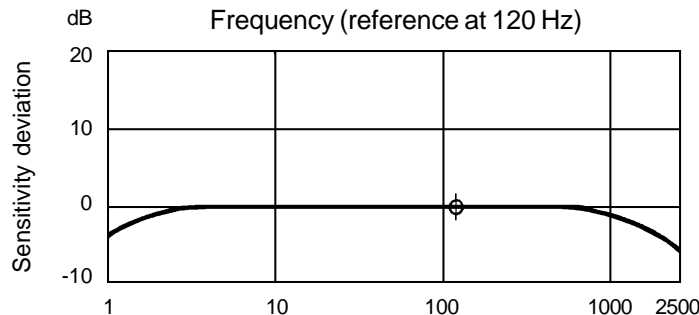

Accessories:

- Stud M5 x 0.5 / 10-32 MA 109 : See drawing 809-109-000 D 01
- Stud M5 x 0.5 / M5 x 0.5 MA 112 : See drawing 809-112-000 D 01
- Differential stud M5 x 0.5 / 10-32 MA 110 : See drawing 809-110-000 D 01
- Triaxial mounting adaptor available

Ordering Information:

- Description / Ordering No : CE 254 / 444-254-000-03 50 mV/g
CE 254 / 444-254-000-13 20 mV/g
MA 109 / 809-109-000-01
MA 110 / 809-110-000-01
MA 112 / 809-112-000-01



Due to the continual development of products, Vibro-Meter reserves the right to modify these specifications without forewarning.

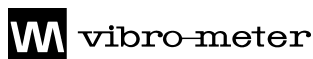

Head Office

Vibro-Meter SA, Rte de Moncor 4,
P.O. Box 1071, CH-1701 Fribourg, Switzerland
Phone : +41 26-407 11 11
Fax Industrial & Marine : +41 26-407 13 01
Fax Aerospace : +41 26-402 36 62
E-mail : vmsa@vibro-meter.ch
Internet : www.vibro-meter.com
www.meggitt.com

Sales Offices in :

- ♦ Germany ♦ France
- ♦ USA ♦ Canada
- ♦ Singapore ♦ United Kingdom
- ♦ Russia ♦ Ukraine

Agents in over 30 countries

Vibro-Meter is a member of the
Meggitt Aerospace Systems Division